

Benchmark Biometric Sensor System for Hearable Devices

Features

- Chest-strap quality optical heart rate (HR) measurement, step rate / count, distance, cycling cadence, calories, R-R interval (RRi) and activity recognition (running/lifestyle)
- The Benchmark[®] sensor and PerformTek[®] processor minimize space impact to the hearable design and provide design flexibility
- Sensor module contains an LED and optical detector with data conversion circuitry mounted to a lens assembly optimized for sensor system accuracy
- PerformTek low-power ARM[®] Cortex[®] processor performs sensor data processing and provides a communication interface to the system Host processor

Figure 1: BE5.0 PerformTek MCU and Sensor

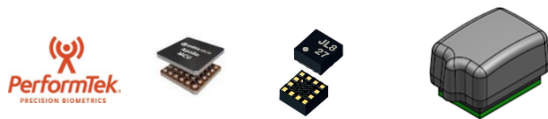

- Sensor Dimensions: 14-pin, 0.6 mm pitch, (5.80 x 3.90 x 3.40) mm
- IMU Dimensions: LGA-12, 0.5 mm pitch, (2.00 x 2.00 x 0.93) mm
- MCU Dimensions: CSP-49, 0.35 mm pitch, (2.56 x 2.59 x 0.45) mm
- 400 kHz I2C or 57.6 kbps UART interface
- Processor and IMU VDD: 1.8 VDC to 3.3 VDC
- Sensor VLED: 2.8 to 5.5 VDC (IR LED Only)

- Sensor VLED: 3.1 to 5.5 VDC (Red + IR LED Only)
- V_{DD} MCU current: 255 μ A standard operation
- V_{LED} Sensor current: 0.11 mA standard operation
- Field updatable processor firmware

Description

The PerformTek powered Benchmark Ear 5.0 (BE5.0) Sensor System is the smallest biometric sensor technology developed by Valencell, Inc. to date. The modular design brings together the best available parts of a successful biometric sensor system in a smaller form factor and includes emitter/detector sensor electronics in an optimized optical package with a processor that is pre-programmed with Valencell's PerformTek advanced biometric algorithms.

Figure 2: BE5.0 Simplified Block Diagram

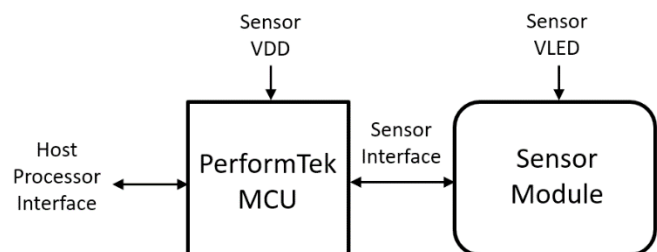

Applications

- In-canal or in-concha wired or wireless headphones
- Hearing aids
- Mono Bluetooth headsets
- Wireless smart audio assistants

Reference Documentation

Table 1: Related Documents

Document	Title
001917	PerformTek Low Power MCU Integration Guide
000638	PerformTek Interface Protocol Document
000964	PerformTek User Guide
002335	PerformTek Low Power Motion Detect Addendum
000532	Benchmark Ear Integration Guide
001926	BE 5.0 Sensor Window Drawing
001913	BE 5.0 Sensor Drawing
001912	BE 5.0 Sensor 3D CAD Model

Change Record

Table 2: Change Record

Author	Revision	Date	Description of change(s)
MEP	01.00	02MAY2019	Initial Release of Preliminary BE5.0 Datasheet
MEP	01.01	02AUG2019	Update based on design finalization. Removed Preliminary marking Removed PerformTek MCU information and added reference to the PerformTek Low Power MCU Integration Guide
SWC	01.02	02DEC2019	Fixed typo on page 16 Corrected the number of components listed in section 9 (from 2 to 3)
SWC	02.00	23DEC2019	Updated sensor dimensions and drawing
MEP	03.00	31MAR2020	Added power information for red LED
MEP	04.00	15OCT2020	Updates based on Official firmware release, version 1742 Updated section 3: <ul style="list-style-type: none"> - Added information for Sleep mode - Updated current consumption - Corrected minimum storage temperature - Increased recommended minimum VLED operating voltage for IR LED to provide additional noise immunity and support for future features

Table of Contents

1	Block Diagram / System Overview	4
2	Sensor Pin Description.....	6
3	Electrical Characteristics	7
4	Sensor Electrical Integration.....	10
5	PerformTek Processor.....	11
6	Additional Electrical Design Guidelines	12
6.1	Power Supply Loading	12
6.2	Mixed Voltage Operation and Power Supply Separation.....	12
6.3	Audio Quality Design Guidelines	12
7	Sensor Physical Integration	14
8	Accelerometer Physical Integration	16
9	Benchmark Sensor Ordering Guide	17
10	Valencell Product Development Design and Test Services	18
11	Contact Information	19
12	Statements	20

1 Block Diagram / System Overview

The Benchmark Ear 5.0 Biometric Sensor solution is provided in three pieces, a sensor, an accelerometer, and a Low Power PerformTek processor. Figure 3 shows how these pieces work together and is described below.

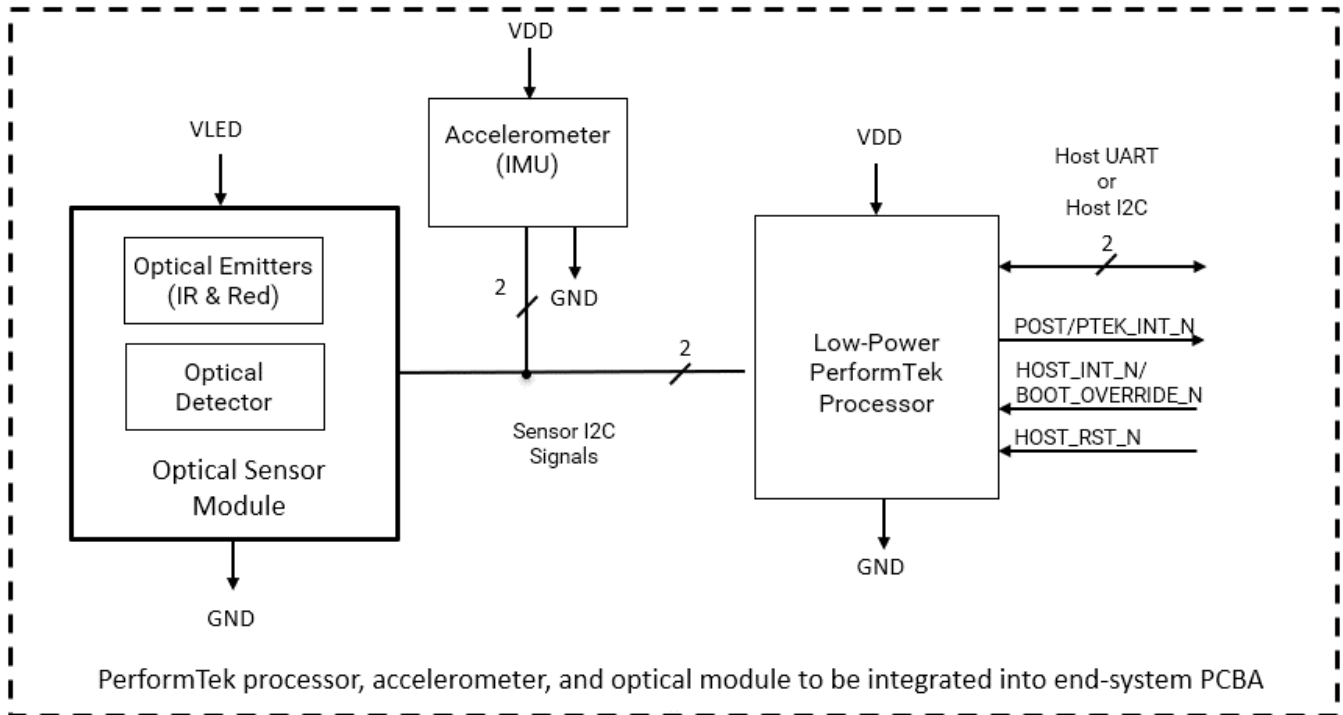

Figure 3: Benchmark Ear 5.0 Functional Block Diagram

On the left of the diagram, the sensor module circuit board contains a digital optical detector system with infrared and red LEDs. The detector and LEDs work together with the accelerometer to collect biometric information via reflected light and movement from the wearer. This information is transmitted over an I2C bus when requested by the PerformTek processor.

The PerformTek processor collects the sensor data and runs Valencell’s patent protected algorithms to convert the raw measurements into biometric values such as heart rate or cadence and processes those values further into higher level user assessments like calories burned. In addition, sensor module diagnostics such as signal quality and error codes are available. This information is available to the Host processor via the Host interface.

The Host interface is shown on the right side of the diagram. Control lines for interfacing the Host processor with the PerformTek processor include an I2C or UART, power-on self-test / sensor interrupt output (POST / PTEK_INT_N), and sensor interrupt / bootloader mode select input (HOST_INT_N / BOOT_OVERRIDE_N). For I2C serial communications with the Host processor, the PerformTek processor acts as the I2C slave role and the Host processor acts as the I2C Master. More details on this interface are provided in the PerformTek Low Power MCU Integration Guide.

2 Sensor Pin Description

Table 3 shows the pin definitions for the sensor. See Section 7 for the physical pinout and package dimensions of the sensor,

Table 3: Sensor Pinout

Pin Number	Symbol	Description
1	SDA	I2C Data Line. Connect to accelerometer and PerformTek Processor
2	SCL	I2C Clock Line. Connect to accelerometer and PerformTek Processor
3	LDO_EN	Connect to VLED
4	LDO	Internal LDO. Connect 1 μ F capacitor to GND_A
5	VLED	Sensor power: Connect VLED power to this pin via a zero Ohm resistor. Option A: Add a 0.1 μ F ceramic capacitor and a 47 μ F polymer tantalum to this pin and GND_L / GND (recommended to reduce risk of audible noise due to piezoelectric effect and to provide path for future design changes that may limit peak current demand from the sensor) Option B: Add a 0.1 μ F ceramic capacitor and a 10 μ F ceramic capacitor to this pin and GND_L / GND (minimum requirement)
6	NC	No Connect
7	NC	No Connect
8	NC	No Connect
9	GND_L	Connect to GND
10	GND_D	Tie to GND_A and connect to GND
11	GND_A	Tie to GND_D and connect to GND
12	VREF	Internal reference for sensor. Connect 1 μ F capacitor between this pin and GND / GND_A
13	NC	No Connect
14	NC	No Connect

3 Electrical Characteristics

The recommended operating conditions of the BE5.0 Sensor are shown in Table 4. See the PerformTek Low Power MCU Integration Guide for information on the PerformTek MCU.

Table 4: Recommended Operating Conditions for Sensor

Parameter	Symbol	Conditions	Min	Typ	Max	Units
Sensor LED Supply Voltage (IR and Red LED Operation) ¹	$V_{LED(RED)}$	Min and Max are inclusive of V_{DD} ripple requirement	3.1	3.3	5.5	VDC
Sensor LED Supply Voltage (IR LED Operation Only)	$V_{LED(IR)}$	Min and Max are inclusive of V_{DD} ripple requirement	3.0 (2.8) ⁴	3.3	5.5	VDC
Sensor ripple voltage ₁₀	$V_{ripple_{10}}$	Sensor system active: 0 to 10 MHz Ripple	-	-	50	mV _{pp}
Sensor ripple voltage ₁₀₀	$V_{ripple_{100}}$	Sensor system active: >10 MHz to 100 MHz Ripple	-	-	100	mV _{pp}
Operating Temperature	-	Device operating in Standby, Idle, or Active Modes	-10	25	50	°C

The operating characteristics of the BE5.0 Sensor are shown in Table 4. See the PerformTek Low Power MCU Integration Guide for information on the PerformTek MCU. For total PerformTek MCU plus sensor power, the current for the sensor shown in this table, should be combined with the information from the PerformTek Low Power MCU Integration Guide.

Table 5: Operating Characteristics of Sensor

Parameter	Symbol	Conditions	Min	Typ	Max	Units
Sensor Current OFF Mode	-	No V _{DD} supply given to sensor module		0		μA
Sensor Current Sleep ⁵ and Idle Modes	-	System is in Standby mode		1.6		μA
VLED Current Active Mode, Standard-Precision RRi, IR LED Only ^{1 6}	-	HR measurement with Standard-precision RRi sampling rate, IR LED only VLED = 3.3 VDC		0.05 to 0.11		mA
Sensor Current Active Mode, Standard-Precision RRi, IR + Red ^{1 6}	-	HR measurement with Standard-precision RRi sampling rate, IR and Red LEDs only VLED = 3.3 VDC		0.09 to 0.20		mA
Sensor Current Active Mode, High-Precision RRi ^{1 6}	-	HR measurement with High-precision RRi sampling rate, IR LED only VLED = 3.3 VDC		0.23 to 0.55		mA
Sensor Current Active Mode, Blood Pressure ^{1 3 6}	-	BP measurement, IR LED only VLED = 3.3 VDC		0.09 to 0.22		mA
Sensor Pulse Current ²	I _{pulse}	System is in Active mode VLED = 3.3 VDC		25		mA

Note 1: The accelerometer is expected to consume approximately an additional 10 uA current from the Vdd rail.

Note 2: It is recommended to allow for at least 62mA pulse current to support future feature updates.

Note 3: Blood Pressure output available on some sensor versions. When operating in this mode, the PerformTek MCU will consume approximately 0.27mA @ 1.8 VDC or 0.26mA @3.3VDC with buck supplies enabled. Contact Valencell for more details.

Note 4: Sensor operation with VLED as low as 2.8VDC is currently supported; however, a minimum supply of 3.0 VDC is recommended to improve power supply noise immunity and ensure compatibility with future features. Contact Valencell if there are any questions or if sensor must support 2.8 VDC operation.

Note 5: See PerformTek Low Power Motion Detect Addendum for more details on this feature.

Note 6: Values listed correspond to normal variation associated with the Optical Trim Feature. The typical value is represented by the highest value shown in this range; however, the Optical Trim Feature may reduce this current in some cases. See the PerformTek User Guide for more details on this feature.

Absolute limits are provided in Table 6. If these limits are exceeded, permanent device damage may occur. Additionally, if the sensor is exposed to these limits for an extended period, the sensor reliability may be impacted.

Table 6: Sensor Absolute Maximum Limits

Parameter	Symbol	Conditions	Min	Typ	Max	Units
Operating Temperature	-	Device operating in Standby, Idle, or Active Modes – performance not guaranteed	-10	-	50	°C
Storage Temperature	-	Device powered off; device will require time to come to equalize with normal operating temperature after exposure to limits of storage temperature	-40	-	85	°C

4 Sensor Electrical Integration

The BE5.0 sensor (U1) is designed to work with the included Low Power PerformTek MCU processor and accelerometer (U2). Connections for this sensor along with the accelerometer are shown in Figure 4. The Low Power PerformTek MCU is not shown in this schematic but should be powered by the same (or equivalent) VDD supply that is shown connected to the accelerometer and should be connected to the nets identified by the orange rectangle.

Figure 4: BE5.0 Sensor Schematic

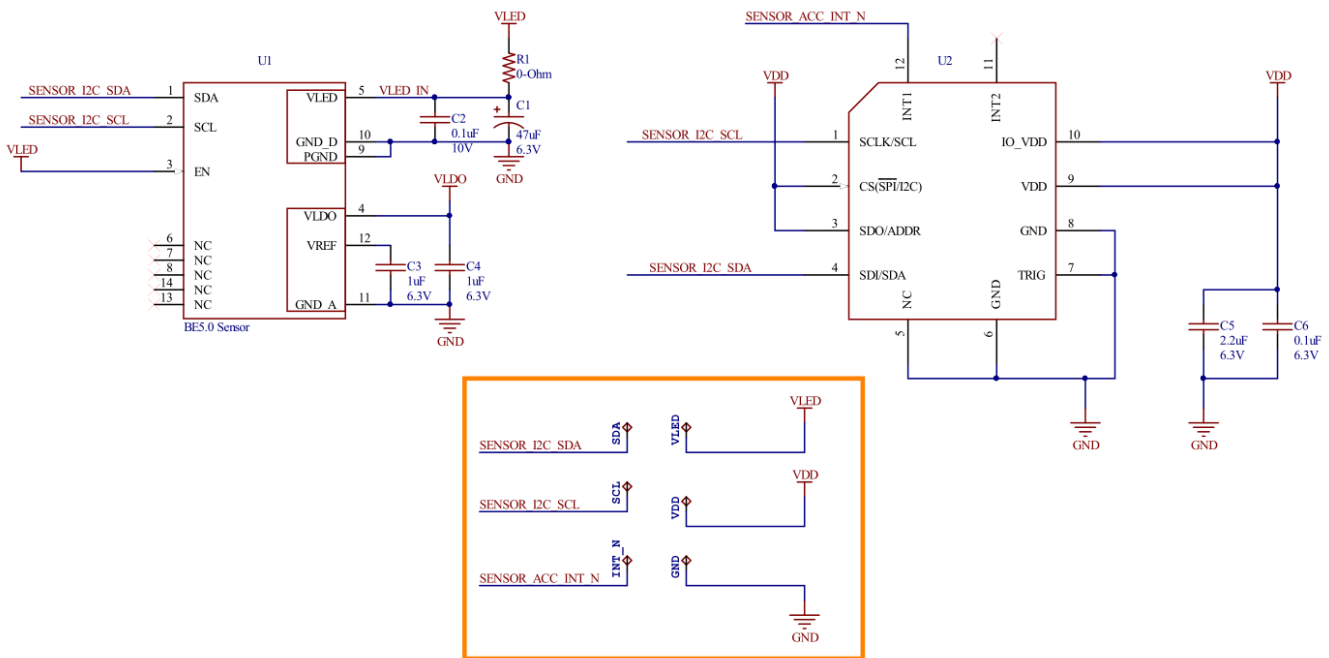

5 PerformTek Processor

The included PerformTek Low Power MCU is implemented on an Ambiq Micro Apollo2 processor. This processor provides significant power savings from Ambiq's patented Subthreshold Power Optimized Technology (SPOT). This is an ARM Cortex-M4 based processor and is provided in a 49-pin Chip Scale Package (CSP).

The processor is programmed by Valencell, Inc. with PerformTek custom firmware and algorithms. See the PerformTek Low Power MCU Integration Guide for interface requirements and integration guidelines.

6 Additional Electrical Design Guidelines

6.1 Power Supply Loading

The system power supply or supplies should be designed to meet the requirements in Section 3 with loading and transients from both the Benchmark sensor, accelerometer, and the PerformTek MCU.

Peak VLED current will be periodic where the period of the peaks will depend on the mode of operation, Heart Rate and Standard-Precision RRi (40 ms) and High-Precision RRi (8 ms). The peak current identified in Section 3 are based on both measured and specified system performance. Processor VDD current peaks are of smaller amplitude and much smaller duration than VLED current peaks. Actual peak and average VDD processor current peak and average numbers will vary depending on the unique characteristics of the system design and how the PerformTek features are used within the system. Because of this, Valencell recommends testing our sensors in a manner representative of their intended use as early as possible in the design cycle. To facilitate this, Valencell supplies development kits that support early prototyping and power measurement and can provide design support and review services upon request.

6.2 Mixed Voltage Operation and Power Supply Separation

The accelerometer and the Low Power PerformTek MCU should be supplied by the same voltage rail (VDD). Generally, the BE5.0 sensor VLED should be supplied by a different power rail than VDD since it allows separation that may be helpful in meeting the ripple requirements of the sensor and it may be desirable to operate the PerformTek MCU and accelerometer at a lower voltage than VLED. In cases where it is desirable to do so, the VDD and VLED rails may be combined if all requirements specified in Section 3 are still met.

6.3 Audio Quality Design Guidelines

While the Benchmark sensor does not generate any perceptible audible noise on its own, it is possible for system power supply noise or crosstalk from the sensor I2C lines to interfere with audio quality if appropriate system design considerations are not followed. To mitigate potential noise issues, design considerations should include:

- Good power and ground plane design and decoupling to minimize conducted system noise into sensor and / or audio cabling
- Appropriate audio circuit and system grounding to ensure any coupled noise is either returned to the system reference as appropriate or blocked by appropriate isolation

- Isolation of audio circuitry signals from sensor I2C, power, and ground lines to minimize crosstalk (This may be accomplished by a combination of PCB routing and or cable design as appropriate)
- Minimize ceramic capacitors exposed to large current transients in locations that could couple audible noise into the ear

7 Sensor Physical Integration

The BE5.0 sensor is shown in Figure 5. Placement and proper integration of the sensor into the hearable system housing is critical for accurate measurement. For enclosure capture feature design and adhesive process guidelines and more complete details on sensor integration, refer to the Benchmark Ear Integration Guide.

The sensor electrical interface geometry is shown in Figure 6. For best performance, the below layout recommendations should be followed

- All bypass capacitors should be placed as close to the part as possible.
- All no connect pins should be soldered down
- All ground pins should be connected to a ground plane
- Avoid sharing vias for decoupling capacitor connections
- Minimize the impedance of power and ground connections

Figure 5: BE5.0 Sensor Images

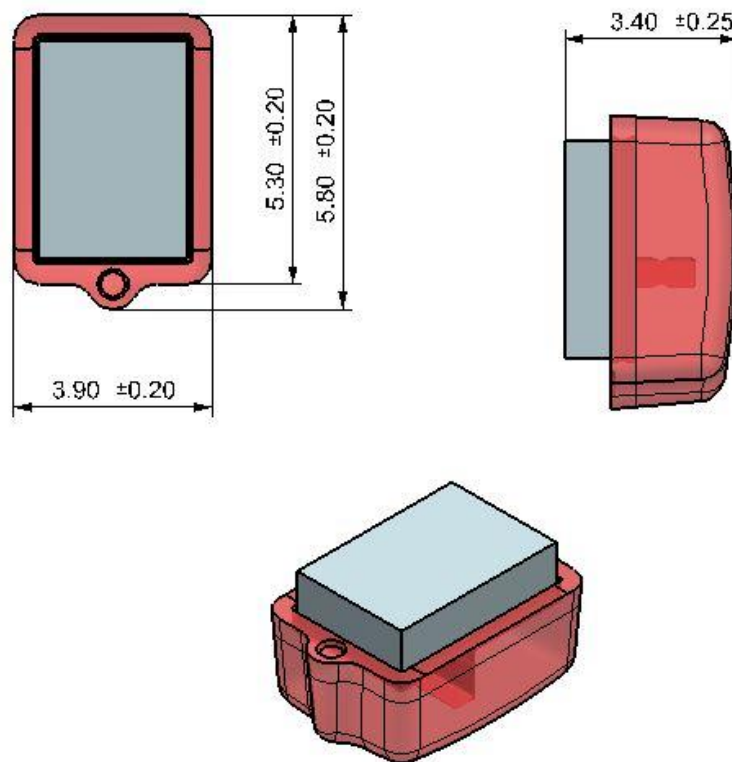
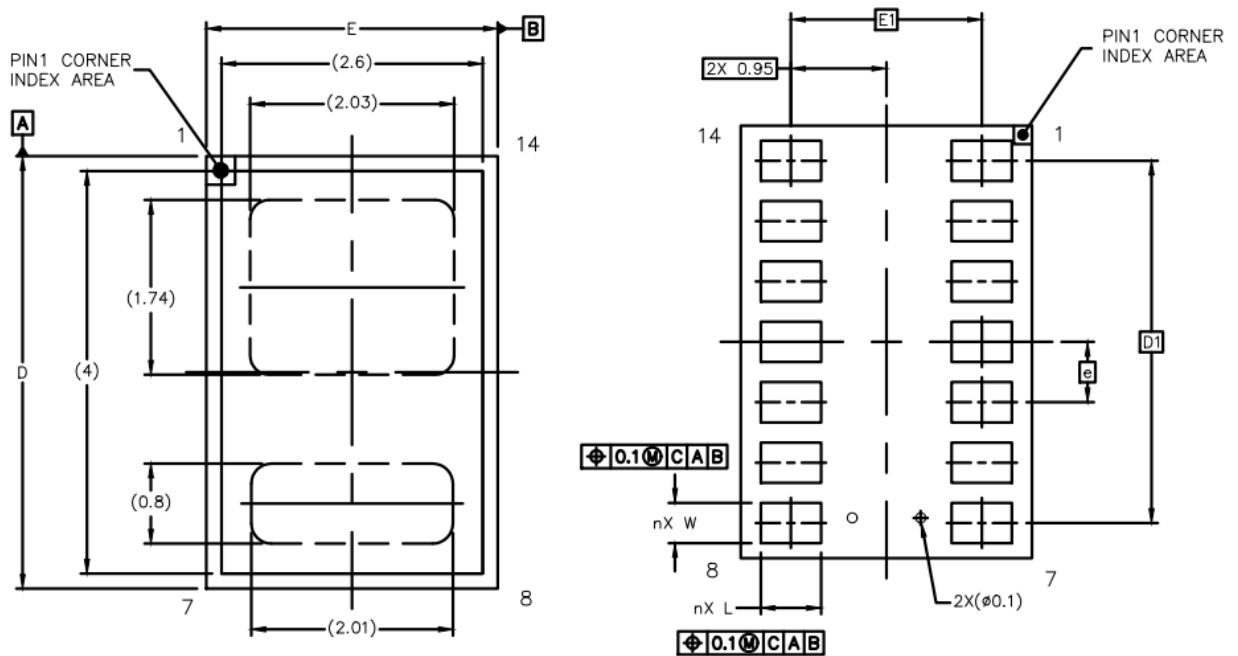

Figure 6: BE5.0 Sensor Drawing and Solder Pads



SYMBOL	COMMON DIMENSIONS		
	MIN.	NOR.	MAX.
A	1.3	1.4	1.5
A1		0.3	REF
A2		0.885	REF
A3		0.2	REF
D	4.2	4.3	4.4
E	2.8	2.9	3
W	0.35	0.4	0.45
L	0.55	0.6	0.65
e		0.6	BSC
n		14	
D1		3.6	BSC
E1		1.9	BSC
aaa		---	
bbb		---	
ddd		0.08	

8 Accelerometer Physical Integration

The accelerometer package and electrical interface geometry is shown in Figure 7. See the Benchmark Ear Integration Guide for additional placement and proper integration guidelines.

Figure 7: BE5.0 Accelerometer Drawing and Solder Pads

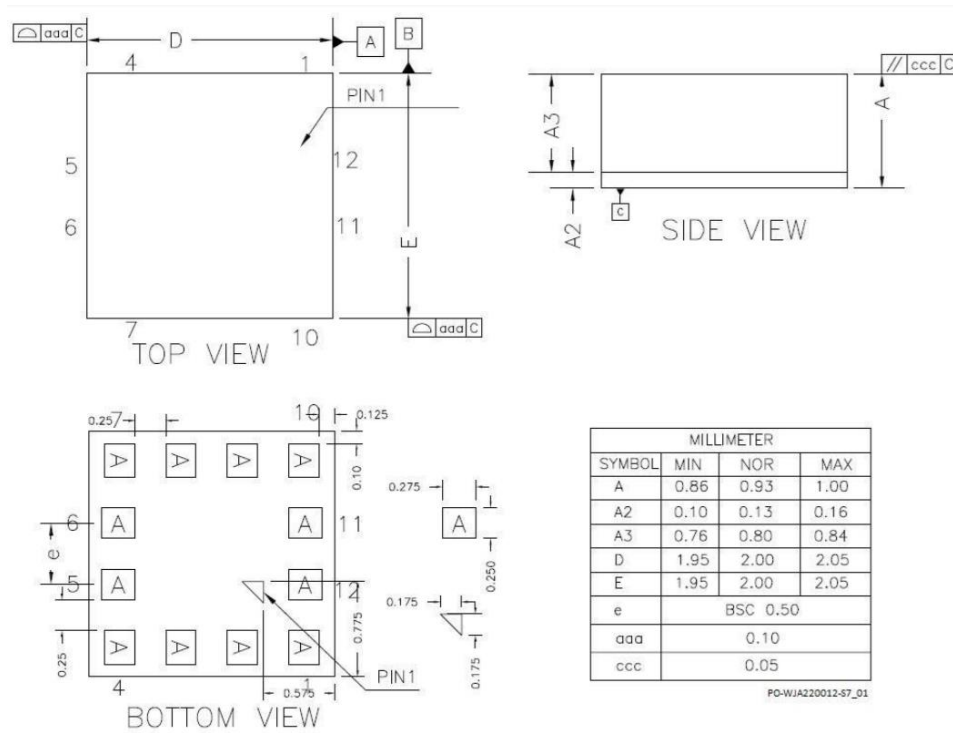

9 Benchmark Sensor Ordering Guide

Part Number	Description
001931	Benchmark Ear 5.0

001931 Benchmark Ear 5.0 consists of a set of three components

BE5.0-Set

1. BE5.0-Sensor
2. BE5.0-Accelerometer
3. BE5.0-AMAPH1KK-KCR

10 Valencell Product Development Design and Test Services

Valencell has years of experience helping customers bring accurate biometric hearable and wearable devices to market. Much of our experience has been captured in application notes and in the integration and user guides, but additional design and test support is available upon request to help reduce your time to market and lower your technical development risks. Our support can span all stages of the product development process, from concept development through mass production and marketing. Design support examples include assisting with placement and mechanical integration of the sensor module within the product being worn; product fit and comfort; power-supply design; and audio design considerations for hearable designs.

Additionally, product performance should be backed by a solid test plan. Valencell has a sophisticated exercise and sport physiology test lab where products using our sensors are tested for proper performance. Our biometric sensors have been tested on thousands of test subjects with the statistical analysis done in a way that conforms to medical and sports journal publication standards. Testing is carried out both indoors and outdoors under many different activities with pools of subjects that have different skin tones, weight, hair, and fitness levels. Results from our sensor tests can be seen in the form of technical white papers on the Valencell website here: www.valencell.com/white-papers. Valencell Labs is located in the U.S. where there is a good diversity of test subjects. Our lab can validate the accuracy and performance of your product design and provide a statistical analysis as part of a design feedback report along with suggestions to improve the product design. This type of testing is the best and only way to know how well your product will perform when introduced into the market.

For more information about our support options, please contact Valencell.

11 Contact Information

For additional information please contact:

Sales Support: benchmark@valencell.com

Technical Support: support@valencell.com



Valencell, Inc.

4601 Six Forks Rd. Suite 103

Raleigh, NC 27609

www.valencell.com

12 Statements

Valencell reserves the right to make changes to its products or example designs as part of its development program. This document and any other related support materials (collectively, the "Materials") are intended to serve as resources only and users should not rely on them to ensure compliance with any laws or requirements.

Benchmark™ and PerformTek™ technology are not designed or authorized for use in life support, medical, or safety critical applications.

THE MATERIALS ARE PROVIDED "AS IS", WITHOUT WARRANTY OF ANY KIND, EXPRESS OR IMPLIED, INCLUDING BUT NOT LIMITED TO THE WARRANTIES OF MERCHANTABILITY, FITNESS FOR A PARTICULAR PURPOSE AND NONINFRINGEMENT. IN NO EVENT SHALL VALENCCELL, INC., BE LIABLE FOR ANY CLAIM, DAMAGES OR OTHER LIABILITY, WHETHER IN AN ACTION OF CONTRACT, TORT OR OTHERWISE, ARISING FROM, OUT OF OR IN CONNECTION WITH THE MATERIALS.

No license is granted or implied under any patent or other rights owned by Valencell, Inc., by the publication or transfer of the information contained herein. Unless otherwise stated, words and logos marked with ® or ™ are trademarks registered or owned by Valencell, Inc. Other products, services and names used in this document may have been trademarked by their respective owners.

Patent Notice:

Protected by granted patents and/or patents pending: www.valencell.com/patents

Both Benchmark® and PerformTek® and the Benchmark and PerformTek designs are registered trademarks of Valencell, Inc. and may not be used for any purpose without the express prior written consent of Valencell, Inc.